

Instruction Manual Transducer Indicator/Controller Model TIC-9000

Macro SensorsTM

Division Of

**Howard A. Schaevitz
Technologies, Inc.**

**7300 Industrial Center, Bldg. 22
U.S. Route 130 North
Pennsauken, NJ 08110-1541**

Phone: 856-662-8000

FAX: 856-317-1005

Description

The TIC-9000 is a single channel, line power-operated LVDT signal conditioner/digital indicator/controller which provides the user with digital indication, and a choice of analog and or RS-232 outputs for use with external indicating, recording or control devices. The TIC-9000 is equipped with 4 limit set-points which with the addition of a relay output option can be used to control processes and alarms directly. The TIC-9000 is a microprocessor based instrument which incorporates several features including the ability to scale in any engineering units and auto-zero, which permits setting of the reading to zero at any point within the LVDT's linear range. The unit is a standard 1/8 -DIN size intended for panel mounting.

Specifications

Power Input.....	115 or 220V AC, 50-60 Hz
LVDT Excitation Voltage.....	1V rms, 3V rms (user selectable)
LVDT Excitation Frequency.....	2.5 kHz, 3.3 kHz, 5 kHz (user selectable)
LVDT Primary Impedance.....	200 Ohms (min.)
Digital Display.....	5 digit (± 99999) 0.4" (10 mm) high efficiency red LEDs
Analog -to-digital Converter.....	16 bit charge balance
Conversion Rate.....	2.5 conversions per second
Settling Time.....	500 ms
Analog Output.....	± 5 VDC
Non-linearity.....	$\pm 0.05\%$, ± 1 count
Analog Output Impedance.....	<10 Ohms
Operating Temperature Range.....	+32°F-+130°F (0°C to +55°C)
Construction.....	Splash-proof front panel

Logic Functions

Setpoint Limits.....	4 (2 high, 2 low)
Setpoint Display.....	Front panel LED indicators (no outputs)
Setpoint Hysteresis.....	User adjustable 0 to 99 counts
Display Calibration.....	Adjustable to any engineering units
Auto-Zero.....	Activated from front panel switch or remotely from rear panel connector

Controls

Front Panel.....	Push button membrane switches
Rear Panel.....	DIP switches

Options

Two or Four setpoint relays.....	5 amp form C
RS-232 Output.....	600-19,200 BPS

TIC-9000 Models	
Model Number	Description
TIC-9000-100	115 Volt Operation
TIC-9000-102	115 Volt Operation, With 2, 5 Amp Relays
TIC-9000-104	115 Volt Operation, With 4, 5 Amp Relays
TIC-9000-110	115 Volt Operation, With RS-232 Output
TIC-9000-112	115 Volt Operation, With 2, 5 Amp Relays, RS-232 Output
TIC-9000-114	115 Volt Operation, With 4, 5 Amp Relays, RS-232 Output
TIC-9000-200	220 Volt Operation
TIC-9000-202	220 Volt Operation, With 2, 5 Amp Relays
TIC-9000-204	220 Volt Operation, With 4, 5 Amp Relays
TIC-9000-210	220 Volt Operation, With RS-232 Output
TIC-9000-212	220 Volt Operation, With 2, 5 Amp Relays, RS-232 Output
TIC-9000-214	220 Volt Operation, With 4, 5 Amp Relays, RS-232 Output

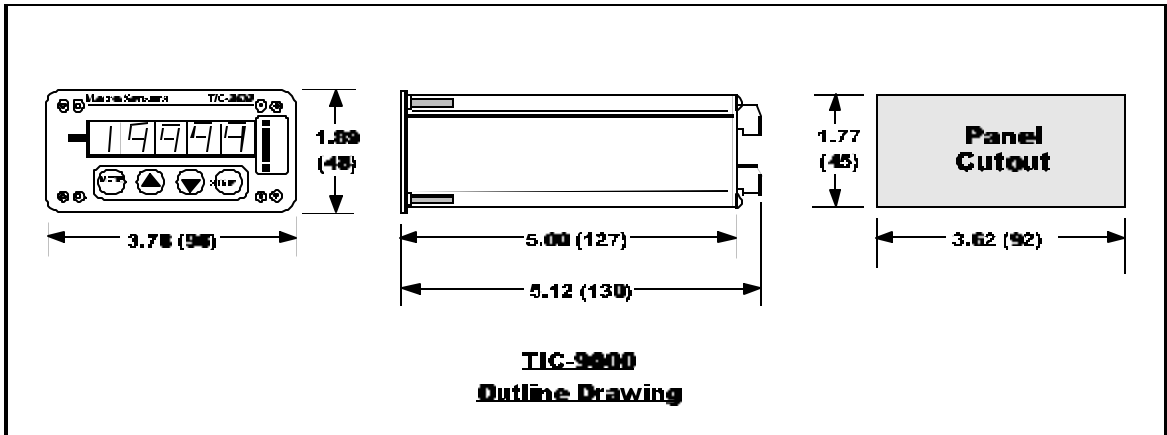

Mounting

The TIC-9000 is designed for panel mounting in a cutout 3.62" (92mm) wide by 1.77" (45mm) high. The unit is secured by use of pawls which engage the rear surface of the panel. The TIC-9000 is designed to mount to panels up to 0.250" (6.35mm) thick.

To mount the unit, rotate outside (pawl screws) counterclockwise to extend pawls to the rear of the unit. Rotate pawls to permit insertion of unit into panel opening.

Rotate pawls to allow engagement of rear surface of panel and tighten screws until unit is secure.

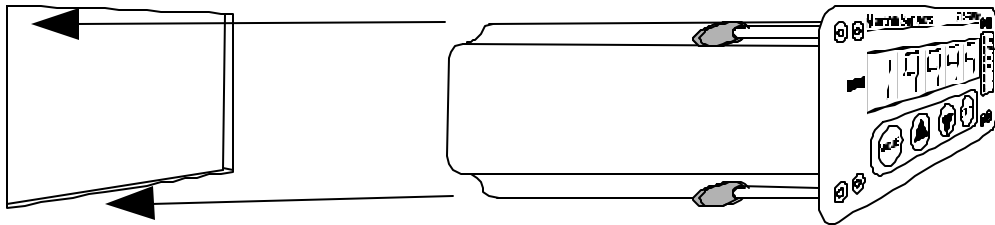

Electrical Connections

Wire connections to the TIC-9000 are made through terminal strips located on the rear panel of the instrument. Terminal strip J1 is used to make power input, LVDT and analog output connections. Terminal strip J2 is used to make connections to the optional 5 amp limit relays and terminal strip J3 is used to make connections to the optional RS-232 output. All terminal strips utilize mating connectors (supplied) which incorporate screw clamp terminals. These screw clamp terminals will accept from #28AWG to #12AWG either stranded or solid wire. Wires should be stripped 5/16" which will provide proper connection without exposing any bare wire. Line power input connections should utilize a minimum gauge of #18AWG. **Be sure to de-energize power line prior to making line power input connections !**

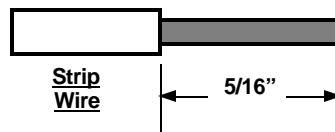

Power Input, LVDT and Output Connections

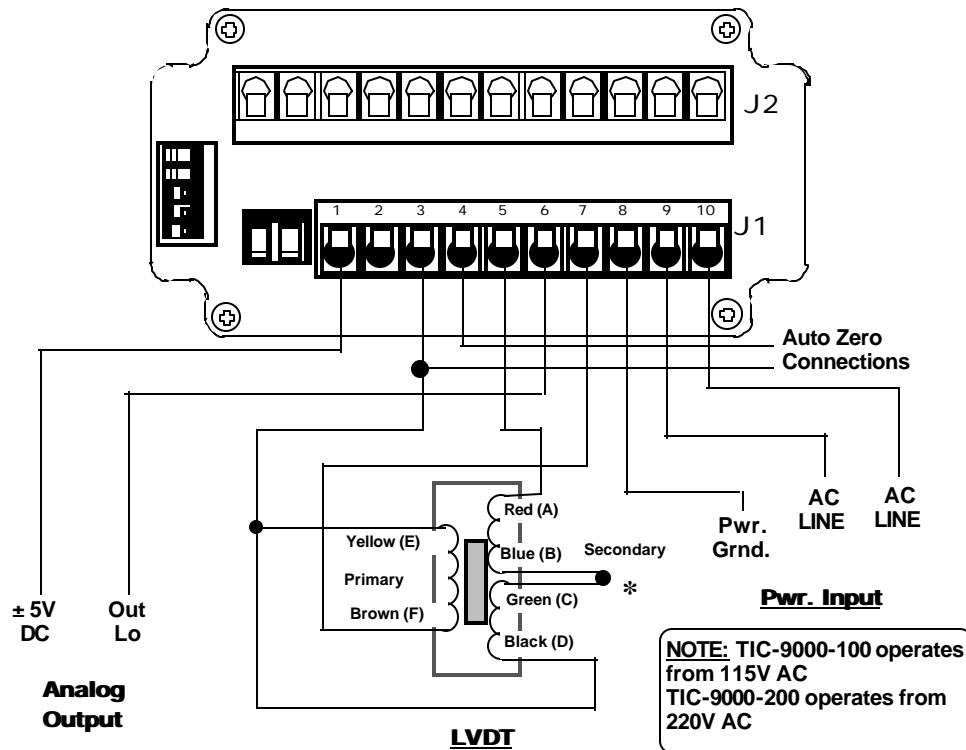

* Note: Blue and Green wires or pins B and C must be connected together

Wiring Note: The wire colors and/or letters shown in the connection diagram apply only to Macro Sensors' standard AC LVDTs with 6 lead wires or 6-pin connectors. For LVDTs with other terminations such as BB series gaging probes or SQ series heavy duty LVDTs, or for extension cables used with LVDTs, consult the data sheet accompanying the LVDT or cable for the correct color codes or terminal connections. Connect the LVDT's primary and secondaries to the signal conditioner according to the wiring diagram, observing the magnetic polarity dots on the LVDT winding schematic.

Extension Cable Connections

Installation may require the addition of an extension cable between the TIC-9000 and the LVDT. Macro Sensors can supply Belden #8786 6-conductor cable for this purpose. Connections should be made in accordance with the diagram shown below. **Note: LVDT center tap should be tied at LVDT or LVDT connector.**

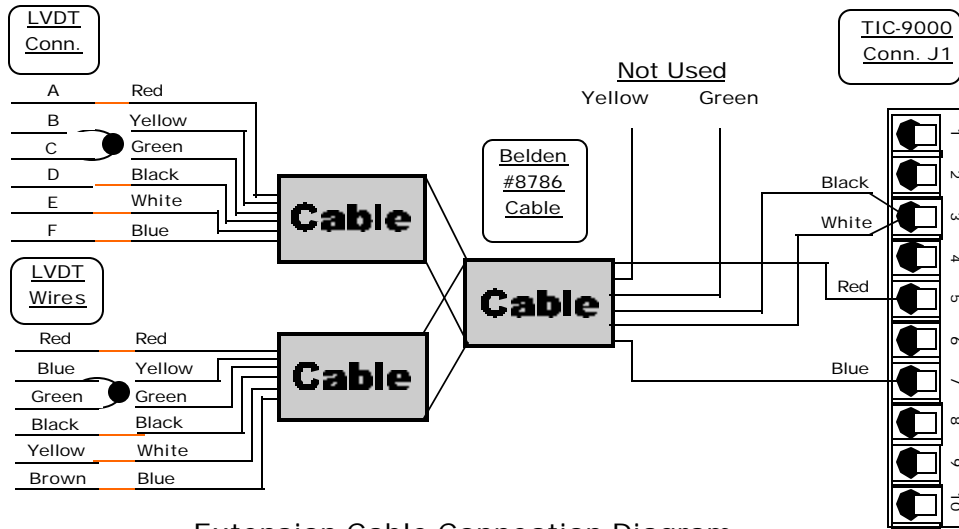

Extension Cable Connection Diagram

Relay Output Connections TIC-9000-102/104, TIC-9000-202/204

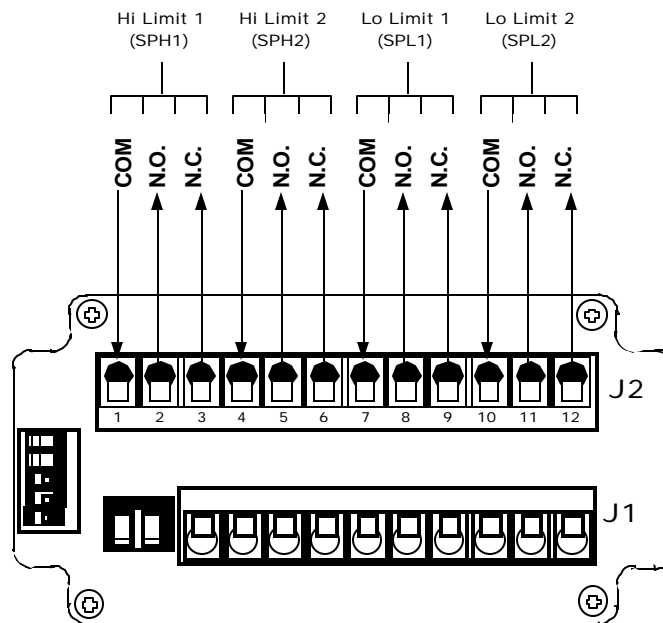

RS232 and Relay Output Connections
TIC-9000-112/114, TIC-9000-212/214

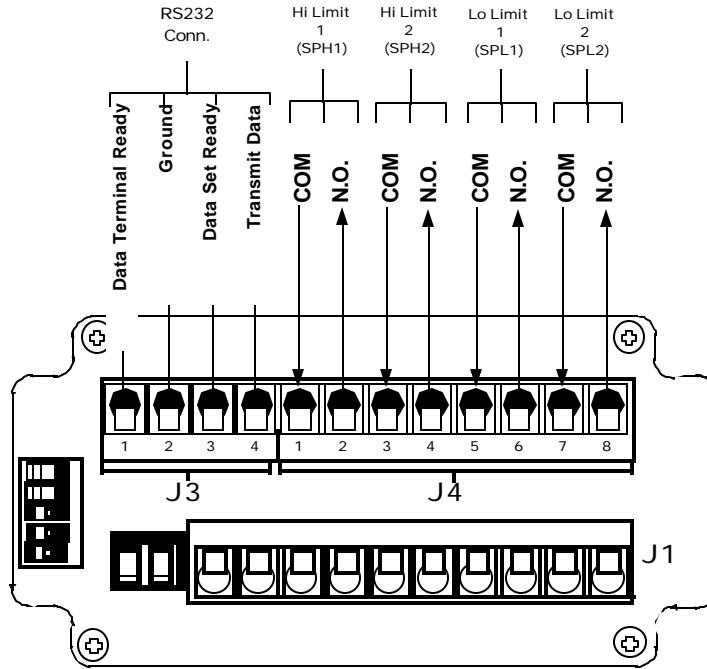

TIC-9000
Front Panel Switch Locations

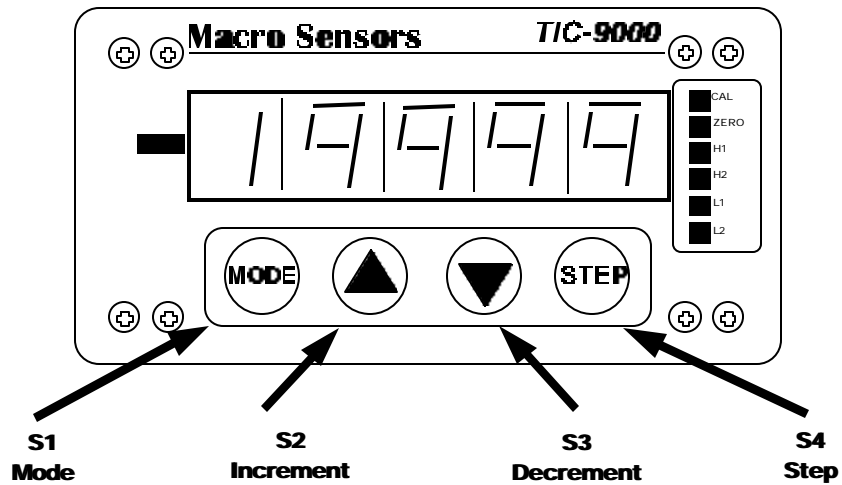

Front Panel Switch Definitions and Functions

Refer to diagram on page 6 labeled TIC-9000 Front Panel Switch Locations

Mode Switch S1

Mode Switch S1 is used to cycle through the 4 setpoints, hysteresis, calibration values and decimal point location. The designations listed in parenthesis below will appear momentarily on the display followed by the value of each respective function. These functions are listed in the order they will be displayed after depressing the Mode Switch. The values of each function are adjusted using the Increment S2, Decrement S3 and/or Step S4.

Set Point High 1	(SPH1)
Set Point Low 1	(SPL1)
Set Point High 2	(SPH 2)
Set Point Low 2	(SPL 2)
Hysteresis High	(HH)
Hysteresis Low	(HL)
Calibration Number	(CAL)
Decimal Point Location	(dP)

To exit these functions, depress the Mode switch S1 after the Decimal Point Location function.

Increment Switch S2

This switch serves two purposes depending on the status of Mode Switch S1. If the Instrument is in the Mode selection sequence, Increment Switch S2 is used to Increment (Increase the value) of the flashing digit on the display. Refer to "Set Up and Operating Instructions" for direction. If the instrument is not in the Mode selection sequence, Increment Switch S2 becomes the Zero or Tare Switch. If the Zero indicator is not illuminated, depressing S2 will cause the instrument to read Zero regardless of the actual position of the LVDT. Depressing S2 with the Zero indicator illuminated will cause the unit to display the reading or value of the actual position of the LVDT and the Zero indicator will extinguish. With the Zero or Auto Tare engaged the value of the Zero position selected will be stored and subtracted from or added to all subsequent readings.

Decrement Switch S3

This switch serves 2 functions, depending on the status of Mode Switch S1. If the instrument is in the Mode selection sequence, Decrement Switch S3 is used to Decrement (Decrease the value) of the flashing digit of the display. If the instrument is not in the Mode selection sequence, S3 becomes the Auto-Cal control. **Caution: Depressing this switch in the operating setting (Non-Mode selection sequence) will cause the instrument to reset its full scale reading.** Refer to Setup and Operating Instructions for further information.

Step Switch S4

This switch serves two functions, depending on the status of switch S1. If the instrument is in the Mode Selection sequence, this switch allows the user to to cycle through the digits on the display. Used in conjunction with switches S2 and S3, it allows the rapid updating of the set point values, hysteresis values, and the Cal value. If the instrument is in the normal operating mode, depressing S4 momentarily will cause the instrument to sequentially display the high and low set point values stored in the instrument's microprocessor. Refer to Setup and Operating Instructions for further information.

Rear Panel Switch Definitions and Functions

Refer to diagram below labeled TIC-9000 Rear Panel Switch Locations.

Switch S5-1 thru 5

This set of switches is used to set operating parameters in the instrument relating to the characteristics of the LVDT being used. They set the LVDT excitation voltage and frequency that the LVDT is to operate at and also set the internal gain characteristics that relate to the LVDT full scale output.

Switch S6-1 thru 2

This set of switches permits the disabling of Front Panel switches S-1 thru S-4 to prevent tampering by unauthorized personnel during normal operation of the instrument. These switches can be set after setup and calibration is complete.

TIC-9000

Rear Panel Switch Locations

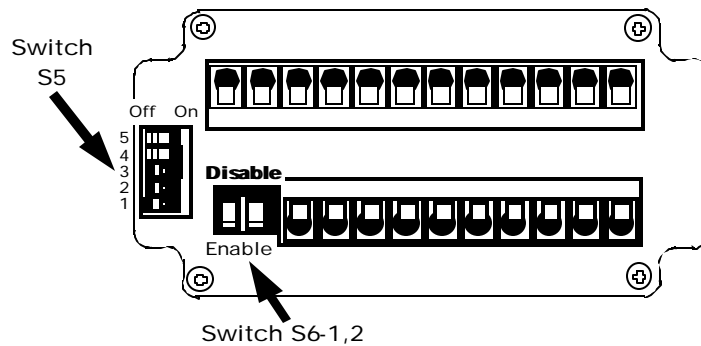

Definition of TIC-9000 Functions

SPH1 (Setpoint #1 High) If the displayed value is equal to or greater than the value set for SPH1, the H1 LED indicator on the front panel will illuminate. If the instrument is equipped with the relay option (-102/202 or -104/204), relay SPH1 will energize.

SPL1 (Setpoint #2 Low) If the displayed value is equal to or less than the value set for SPL1, the L1 LED indicator on the front panel will illuminate. If the instrument is equipped with the relay option (-102/202 or -104/204), relay SPL1 will energize.

SPH2 (Setpoint #3 High) If the displayed value is equal to or greater than the value set for SPH2, the H2 LED indicator on the front panel will illuminate. If the instrument is equipped with the relay option (-104 or -204), relay SPH2 will energize.

SPL2 (Setpoint #4 Low) If the displayed value is equal to or less than the value set for SPL2, the L2 LED indicator on the front panel will illuminate. If the instrument is equipped with the relay option (-104 or -204), relay SPL2 will energize.

HH (Hysteresis High) This value determines the hysteresis or deadband below the values set for SPH1 and/or SPH2.

Example: If HH is set to a value of 02 and SPH1 and SPH2 are both set for a value of 100, setpoint limits H1 and H2 will actuate when the displayed reading is equal to or greater than 100, but will not turn off until the displayed reading is equal to or less than 98.

HL (Hysteresis Low) This value determines the hysteresis or deadband above the values set for SPL1 or SPL2.

Example: If HL is set to a value of 02 and SPL1 and SPL2 are both set to 100, setpoint limits L1 and L2 will actuate when the displayed reading is equal to or less than 100, but will not turn off until the displayed reading is equal to or greater than 102.

CAL (Calibration Number) This number is used to setup the instrument in preparation for final calibration. This number represents the maximum full scale reading to be displayed during normal operation (Maximum full scale.)

Example: If the TIC-9000 is to be calibrated with an LVDT having a full scale of 4 inches, the CAL number should be set to 4.000 or 4.0000 since the instrument is capable of displaying up to 99,999 counts. However the resolution of the A/D converter is only 19,999 counts, so if the CAL number is 4.0000, the display will count by 2's. The microprocessor in the instrument will automatically make this decision when the instrument is calibrated. For best

resolution, it is desirable to keep the CAL number setting at or below 19,999. See the Calibration Instructions for more information.

DP (Decimal Point) The decimal point can be located in any position desired.

MIN/MAX The readings displayed when switch S4 is depressed are the minimum and maximum readings made by the TIC-9000 after line power was applied. If unit is de-energized or power is interrupted, all prior MIN/MAX readings will be lost.

Analog Output An analog output of up to ± 5 V DC is available from terminals 1 and 6 on connector J1. This analog output is the demodulated DC output from the LVDT signal signal conditioner contained in the instrument and is not adjustable.

Setup and Operating Instructions

Wiring and Connections The TIC-9000 should be connected in accordance with the appropriate wiring instructions as shown on pages 4,5, and 6.

Setting TIC-9000 LVDT Operating Parameters Three LVDT operating parameters must be set to ensure that the signal conditioner is matched to the characteristics of the LVDT being used. These parameters include LVDT excitation voltage and frequency and LVDT full scale output to the instrument. This is accomplished by setting switch S5-1 through 5 to the settings indicated in the chart on page 10.

LVDT Excitation Voltage The TIC-9000 has 3 selectable LVDT excitation voltages. The desired voltage is normally set to match the specifications and/or recommended operating voltage for the LVDT being used. As shipped from the factory, the TIC-9000 is set to provide 5 V rms excitation voltage. Excitation voltage may be change by setting switches S5-4 and S5-5 to the desired setting as indicated in the chart on page 11.

LVDT Excitation Frequency The TIC-9000 has three selectable LVDT excitation frequencies. As with excitation voltage, the LVDT excitation frequency should be set as closely as possible to the specifications and/or recommended excitation frequency for the LVDT being used. As shipped from the factory, the TIC-9000 is set to provide a 2.5 kHz frequency. The LVDT excitation frequency may be changed by setting switches S5-2 and S5-3 to the desired settings as indicated in the chart on page 10.

LVDT Full Scale Input The TIC-9000 can operate with LVDTs having a wide range of sensitivities. Full Scale AC input from the LVDT to the instrument must be selected to insure proper operation. Determine the AC full scale input by performing the following calculation:

Sensitivity in Volts/.001" X Excitation Voltage X Full stroke in thousandths of an inch = Full Scale Input (V AC rms)

Example 1: ± 0.050 Stroke LVDT

Sensitivity: $0.0055\text{V}/.001"$ X 3V rms X 50 (1/2 range in .001") = 0.825V rms Full Scale Input. Switch S5-1 should be set for 1V rms.

Example 2: ± 3.000 " Stroke LVDT

Sensitivity: $0.0008\text{V}/.001"$ X 1V rms X 3000 (1/2 range in .001") = 2.4V rms Full Scale Input. Switch S5-1 should be set for 3V rms.

Switch S5-1 Through -5

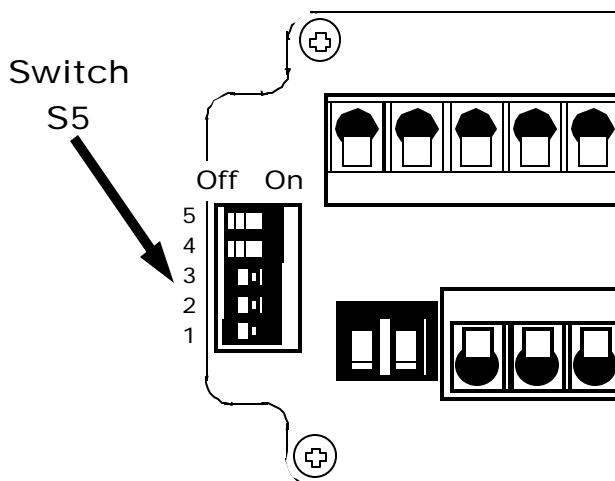

TIC-9000 LVDT Operating Parameter Chart						
Parameter	S5-1	S5-2	S5-3	S5-4	S5-5	Value
LVDT Excitation Voltage				On	On	1V rms
				Off	On	3V rms
				Off	Off	5V rms
LVDT Excitation Frequency		On	On			2.5k Hz
		Off	On			3.3k Hz
		Off	Off			5k Hz
LVDT Full Scale Input	Off					1V rms
	On					3V rms

Turn On Instructions

Apply line power to instrument. Verify that the TIC-9000 readout blanks momentarily and then displays the value of the LVDT input signal. **Caution: If the digital display is blank or dim, de-energize unit immediately and recheck to be sure that input power connections are correctly installed.**

Programming Instructions

The following steps are accomplished using Switches S1 Through S4. Refer to diagram on page 6 entitled "TIC-9000 Front Panel Switch Locations".

Depress Mode switch (S1) once.

The text SPH1 will appear followed by the current set value of setpoint #1 high. The most significant digit will be flashing. The set value of this digit may be increased (made more positive) by depressing Switch S2 or decreased (made less positive) by depressing switch S3. Depressing Switch S4 will select the next least significant digit for updating. Again, depress switches S2 or S3 to set the desired value for this digit. Depressing S4 will continue to select the next least significant digit and permit setting of each respective digit's value. Continue this procedure until all digits for SPH1 are set to the desired values.

Depress Mode Switch (S1) Again

The text SPL1 will appear followed by the current set value of setpoint #1 low. Repeat the procedure followed for SPH1 until all digits for SPL1 are set to the desired values.

(Next Page)

Depress Mode Switch (S1) Again

The text SPH2 will appear followed by the current set value of setpoint #2 high. Repeat the procedure followed for SPH1 until all digits for SPH2 are set to the desired values.

Depress Mode Switch (S1) Again

The text SPL2 will appear followed by the current set value of setpoint #2 low. Repeat the procedure followed for SPH1 until all digits for SPL2 are set to the desired values.

Depress Mode Switch (S1) Again

The text HH will appear followed by the current set value of hysteresis or deadband high. See "Definition of Functions" on page 8 for a detailed description of this function. The most significant digit will be flashing. The set value of this digit may be increased (made more positive) by depressing switch S2 or decreased (made less positive) by depressing switch S3. Depressing switch S4 will select the next least significant digit for updating. Again, depress switches S2 or S3 to set the desired value for this digit. The maximum value for this function is 99 counts.

Depress Mode Switch (S1) Again

The text HL will appear followed by the current set value of hysteresis or deadband low. See "Definition of Functions" on page 8 for a detailed description of this function. The most significant digit will be flashing. The set value of this digit may be increased (made more positive) by depressing switch S2 or decreased (made less positive) by depressing switch S3. Depressing switch S4 will select the next least significant digit for updating. Again, depress switches S2 or S3 to set the desired value for this digit. The maximum value for this function is 99 counts.

Depress Mode Switch (S1) Again

The text CAL will appear followed by the current set value of CAL (Calibration Number). See "Definition of Functions" on page 8 for a detailed description of this function. The most significant digit will be flashing. The set value of this digit may be increased (made more positive) by depressing switch S2 or decreased (made less positive) by depressing switch S3. Depressing switch S4 will select the next least significant digit for updating. Again depress switches S2 or S3 to set the desired value for this digit. Depressing S4 will continue to select the next least significant digit and permit setting of each respective digit's value. Continue this procedure until all digits for CAL are set to the desired values.

Depress Mode Switch (S1) Again

The text DP will appear followed by display of the current decimal point position. Depressing switches S2 or S3 will cause the decimal point to move to the desired position.

Depress Mode Switch (S1) Again

The TIC-9000 will exit the Mode Selection Sequence and enter the normal operating mode. The instrument is now ready for calibration with the LVDT being used.

Calibration Instructions

The following steps are required to provide proper calibration of the LVDT with the TIC-9000. If unit was previously calibrated, no further action is necessary. All calibration data is stored in non-volatile memory, so unit will be ready for normal operation when line power is applied.

Apply Line Power Prior to proceeding to the next step, be sure that CAL number has been entered.

This value should have been entered during the Programming Instructions sequence. If this value was not entered, refer to the Programming instructions, Step 7, "CAL" on this page.

Verify That TIC-9000 Is Out Of Menu Sequence Unit should be reading LVDT input value. The Zero and CAL LED indicator should be illuminated.

Depress Switch S2 Once The ZERO LED indicator should extinguish.

Set LVDT To Its Null Position Move LVDT core or LVDT body until digital display indicates 00000. This position is true LVDT null position and the reference point from which subsequent position measurements are made.

Note: This step is extremely important to assure that LVDT will be operating within its rated linear range !

Depress Switch S2 Again Verify that the Zero LED indicator illuminates. The digital display should now be reading 00000.

Depress Switch S3 The CAL LED indicator will extinguish.

Move LVDT core precisely to its fully extended or retracted Position This should be accomplished using gage blocks, shims, micrometer or other precision displacement input device.

Depress Switch S3 Once Verify that the CAL LED indicator is illuminated and verify that digital display reads previously set full scale (CAL) value.

Unit is now ready for normal operation.

Directional Sense

If the slope of the analog output voltage and digital display is the reverse of the desired slope, i.e., if the output voltage and digital display increases or decreases opposite to the desired direction of core motion, reverse the LVDT secondary connections to terminals 3 and 9

RS-232 Option

Description The TIC-9000 may be equipped with the optional RS-232 communication assembly which permits transmission of serial digital data displayed by the instrument to computers or other external digital data collection devices. This option consists of an additional PC board assembly with necessary circuitry and baud rate setting control to permit transmission of this data.

Baud Rate The RS-232 option board is equipped with settable baud rates of from 600 to 19,200. The baud rate is set using a 4 position DIP switch located on the option board. Baud rate should be specified at time of ordering and will be pre-set at the factory. If not specified, the baud rate will be set at 1200. Refer to the diagram on page 13 for the location of this DIP switch.

Data Format No PARITY bit
1 STOP bit
8 DATA bits

Data Transmission Data is transmitted in ASCII characters

Data Transmission Sequence

1. Sign: Plus or minus (1st word)
2. Magnitude: MSD first (2nd thru 6th word)
3. Decimal Point: Exponent (7th word)
4. EOL: Control Z (8th word)

Decimal Point Position as a Power of 10 Exponent

- X.XXXX 4 (ASCII)
- XX.XXX 3 (ASCII)
- XXX.XX 2 (ASCII)
- XXXX.X 1 (ASCII)

Data Update Data is transmitted once per conversion cycle if the Data Set Ready (DSR) line is TRUE (logical "1"). Once transmission is started, all 8 words are transmitted independently of DSR. The state of DSR is ignored until all words are transmitted. Data Terminal Ready (DTR) is set TRUE (logical "1") when meter is active.

Baud Rate Switch Settings (Switch S7)				
Baud Rate	S7-1	S7-2	S7-3	S7-4
600	Off	On	ON	On
1200	On	Off	Off	Off
2400	On	Off	On	Off
4800	On	On	Off	Off
7200	On	On	Off	On
9600	On	On	On	Off
19200	On	On	On	On

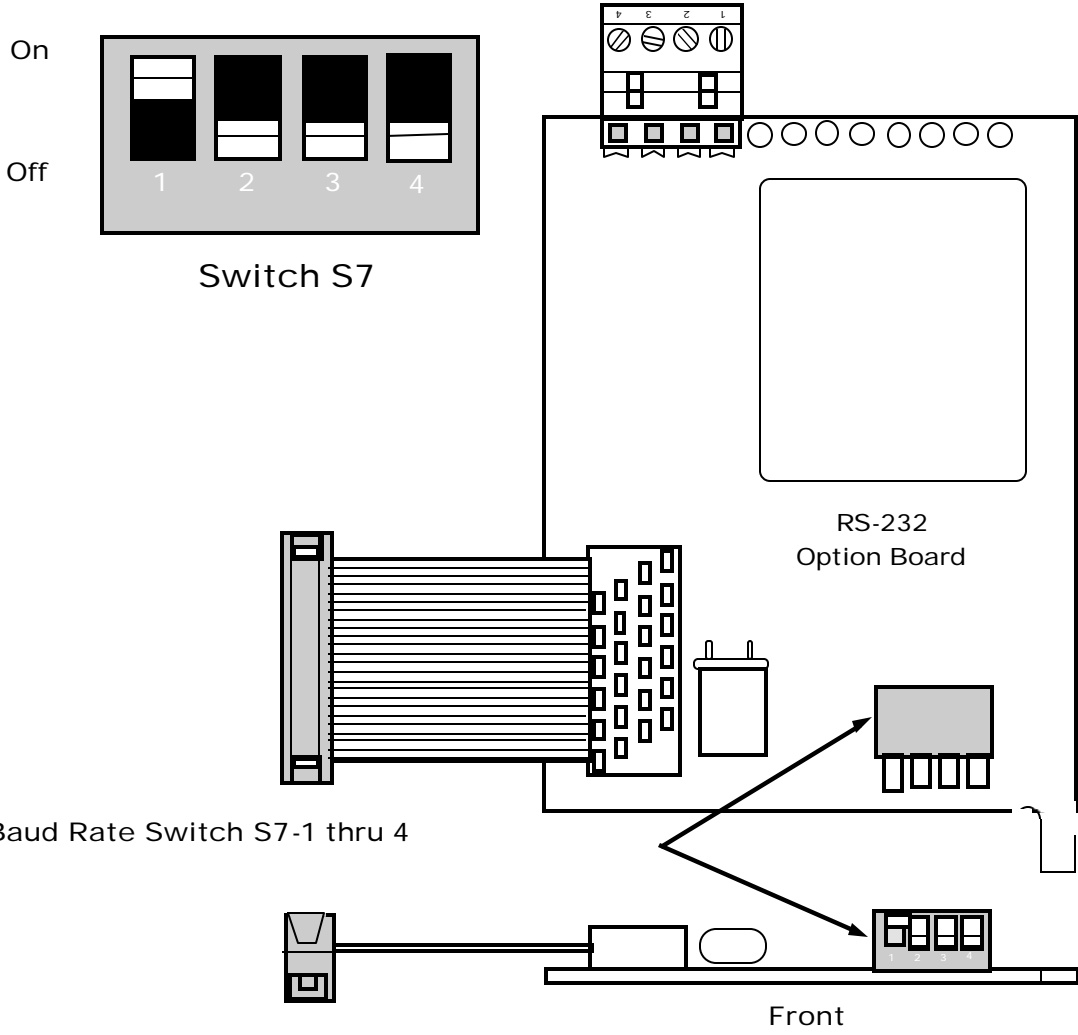

TIC-9000 Program Diagrams

