

**Instruction Manual**  
**Low Voltage**  
**DC-Operated**  
**Modular LVDT**  
**Signal Conditioner**  
**Model LVC-2412**

**MACRO SENSORS™**  
*Division Of Howard A. Schaevitz Technologies, Inc.*

***Innovators in Position Measurement Products***

**7300 U.S. Route 130 North, Bldg. 22**

**Pennsauken, NJ 08110-1541 U.S.A.**  
**Phone: 856-662-8000 Fax: 856-661-8000**

## DESCRIPTION

The LVC-2412 is a low voltage DC-powered single channel signal conditioner module capable of operating most LVDTs, RVDTs, and VRT half-bridges. Powered from either 12 or 24 Volts DC, an LVC-2412 includes all the circuitry required to energize an LVDT position sensor and provide a high level low noise analog DC voltage output or a 4-20 mA sourcing current loop output to analog or digital indicators, PLCs, and other control system instrumentation. Besides featuring non-interactive front-panel **Span** and **Zero** adjustment, LVC-2412 modules offer user-selectability of 3 excitation frequencies and 4 coarse gain steps to operate sensors having widely different sensitivities. The case mounts on either DIN 1 or DIN 3 rails, with eurostyle recessed-and-protected screw clamp terminals at the top and bottom of the case for I/O connections. Case dimensions are shown in the outline drawing on page 12.

## SPECIFICATIONS

Power Input ..... 18 - 30 V DC (24 V nom., 125 mA max.)  
or ..... 9 - 15 V DC (12 V nom., 250 mA max.)  
LVDT Excitation Voltage ..... 3 Vrms nom.  
LVDT Excitation Frequencies ..... 3, 5, or 10 kHz nom.  
LVDT Primary Impedance ..... 200 Ohms min.  
Full Scale Output  
    Voltage Mode ..... 0 to  $\pm 10$  V DC, 5 mA max.  
    Current Loop ..... 4 - 20 mA sourcing, 500 Ohm loop max.  
Frequency Response (-3dB) ..... 250 Hz nom.  
Output Noise and Ripple ..... 5 mVrms or 10  $\mu$ Arms max.  
Output Impedance ..... <10 Ohms  
Non-linearity .....  $\pm 0.01\%$  FSO max.  
Operating Temp. Range ..... 0°F to +160°F (-18°C to +70°C)  
Temp. Coeff. of Sens. .... 0.01% FSO/°F (0.018% FSO/°C)  
Front Panel Controls ..... 20-turn Zero and Span

## **MOUNTING**

The LVC-2412 mounts on 32 mm x 15 mm asymmetrical DIN 1 rail or 35 mm x either 7.5 mm or 15 mm symmetrical DIN 3 rail. For dimensions, refer to the module outline drawing on page 12.

## **INSTALLATION NOTES**

LVC-2412 LVDT signal conditioning modules require adequate ventilation for proper functioning and reliable operation. Follow the installation guidelines below to assure adequate ventilation.

**LVC-2412 modules should be mounted vertically (upright).** Horizontal (flat) mounting is not recommended. (This means the DIN rail should be mounted horizontally.)

**Allow at least 5/8 inch (16 mm) air space between modules mounted side by side.** To maximize space utilization, mount low-height junction blocks, fuse holders, etc. between units.

**Do not block the airflow around and through the modules.** If necessary, use a fan or blower to force ventilation air through the vent louvers around the module case.

**Do not mount an LVC or LPC module in line with another.** For better ventilation and convection airflow, stagger module locations so warm air rising from a lower unit does not flow into the vent louvers of a module mounted higher up.

### **Special installation precaution for LVC-2412 modules in 4-to-20 mA current output mode**

An LVC-2412 module sources 4 to 20 mA into a current loop. It should never be connected into a loop-powered transmitter circuit, because the power for the module's current loop comes from the LVC module, not from a separate loop power supply.

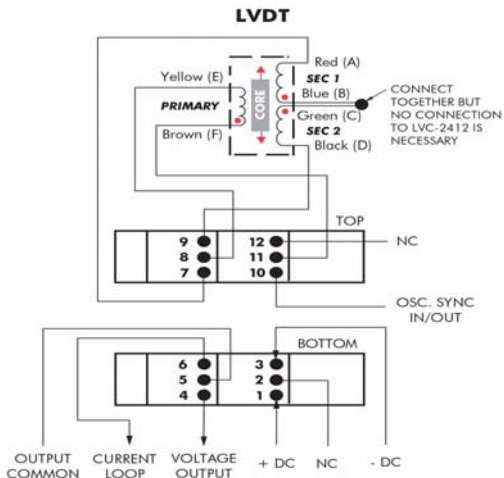

**Wiring Note:** The wire colors and/or letters shown in this connection diagram apply only to Macro Sensors' standard LVDTs with 6 leads or 6-pin connectors. For LVDTs with other terminations such as BB series gaging probes, SQ series heavy duty LVDTs, or for extension cables used with LVDTs, consult the data sheet accompanying the sensor or cable for the correct color codes or terminal connections. Connect the LVDT's primary and secondaries to the signal conditioner according to the wiring diagram, observing the magnetic polarity dots on the LVDT schematic. For LVDT and VR half-bridge connections, see the notes on page 11.

## CONNECTIONS

I/O wiring for an LVC-2412 is connected to industry-standard recessed-and-protected screw clamp terminals that can accept either solid or stranded wire sizes from 28 AWG to 12 AWG. Wires should be stripped 5/16 inch (8 mm), which gives proper length of conductor without exposing any bare wire. DC power input wiring should utilize 22 AWG minimum conductor size.

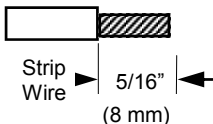

## INTERNAL ACCESS

To gain access to the inside of an LVC-2412 to set gain jumpers or to reset or sync LVDT excitation frequency, **first, shut off the DC power to the module.** Then use a thin screwdriver, knife blade, or a similar thin tool to pry off the side cover at points indicated in figure.

After jumpers are moved, snap cover on by pressing on projecting retainer sites.

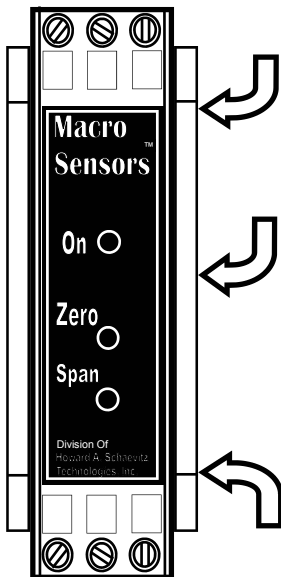

## EXCITATION FREQUENCY SELECTION

The LVC-2412 offers three user-selectable LVDT excitation frequencies. This frequency is normally chosen to be close to the specified or recommended operating frequency of the LVDT being used. Frequency is selected by moving a shorting bar jumper on S1, S2, or S3 (see Figure 1 on page 7). The factory set excitation frequency is nominally 3 kHz, a very common excitation for many LVDTs, using a jumper installed on S1. Referring to *INTERNAL ACCESS* on page 5, remove the right side cover and move the jumper from S1 to S2 for a nominal 5 kHz, or from S1 to S3 for a nominal 10 kHz.

## COARSE GAIN SELECTION

Coarse gain selection is provided so the LVC-2412 can operate with LVDTs having a wide range of sensitivity factors. To properly set coarse gain, the full scale AC output of the LVDT must be calculated from the LVDT's sensitivity, which is typically published as V/V/inch or mV/V/mil (1 mil=0.001 inch), as shown in the following formulas and example calculations.

Full Scale Output (V ACrms) = **Sensitivity** in Volts/Volt/inch X  
**Excitation Voltage** (ACrms) X **Full Scale Stroke** in inches  
*or*

Full Scale Output (V ACrms) = **Sensitivity** in mV/V/mil X  
**Excitation Voltage** (ACrms) X **Full Scale Stroke** in mils

### **Example 1: PR 750-050 ±0.050 inch stroke LVDT**

Full Scale LVDT Output = 6.5 mV/V/mil (sensitivity) X 3 V  
ACrms (excitation) X 50 (full scale in mils) = 0.975 V ACrms

### **Example 2: PR 812-1000 ±1.00 inch stroke LVDT**

Full Scale LVDT Output = 0.65 V/V/inch (sensitivity) X 3 V  
ACrms (excitation) X 1.0 (full scale in inches) = 1.95 V ACrms

Referring to *INTERNAL ACCESS* on page 5, remove the right side module cover. Select coarse gain by placing shorting bar jumpers on S4, S5, S6, and S7 according to the table below. Replace the side cover when all jumper selecting is completed. Placing jumpers as instructed will yield a  $\pm 10V$  DC full scale output.

<b>COARSE GAIN SELECTION TABLE</b>				
<b>LVDT Full Scale Output V ACrms</b>	<b>S4</b>	<b>S5</b>	<b>S6</b>	<b>S7</b>
0.07 V - 0.3 V	Open	Open	Open	Open
0.31 V - 0.6 V	Open	<b>Jumper</b>	Open	Open
0.61 V - 2.5 V	Open	<b>Jumper</b>	Open	<b>Jumper</b>
2.51 V - 5.5 V	<b>Jumper</b>	Open	<b>Jumper</b>	Open

■ Indicates jumper positions as shipped from factory

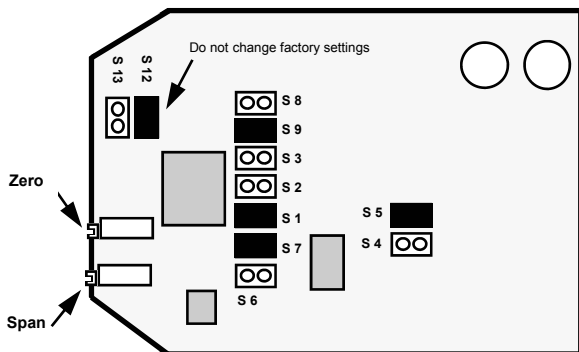

**Figure 1**

## MULTI-CHANNEL APPLICATIONS

Where several LVC-2412s are operated in close proximity to each other, synchronizing their excitation oscillators to the same frequency can prevent heterodyning or beating between units. Up to 8 modules can be synchronized in one network. For more than 8 modules, use additional independent networks. Referring to *INTERNAL ACCESS* on page 5, *EXCITATION FREQUENCY SELECTION* on page 6, and *Figure 1* on page 7, remove the right side cover from each module and set the jumper on S1, S2, or S3 to the same frequency for each module. To synchronize all the modules' oscillators, designate one module as "master" and the rest as "slaves". For the master, move the sync jumper from S8 to S9, but leave the sync jumper on S8 for each slave. After replacing the side cover, interconnect terminal 10 on all the modules and interconnect terminal 3 on all the modules. If sync line noise is a problem, connect terminal 3 to 5 on each module.

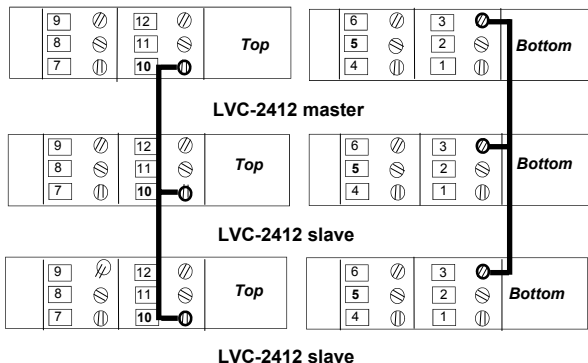

**Auxiliary connections for multiple LVC-2412s being operated in master/slave configuration**

## BIPOLAR VOLTAGE OUTPUT CALIBRATION

To calibrate the module for bipolar voltage output, remove the LVDT secondary wire, usually Red (A), from terminal 7. Install a temporary jumper between terminals 7 and 9 (this jumper will be removed after zero adjustment). Apply DC power to unit and allow a 3-5 minute warm up. Adjust the **Zero** control to produce an output of 0 V DC between module terminals 4 and 5. De-energize the module, remove the temporary jumper from terminals 7 and 9, and re-connect the secondary wire, Red (A), to terminal 7. Re-apply DC power to unit and move the LVDT's core or body until the output again reads 0 V DC. This position is the null point of the sensor and the reference point from which subsequent measurements are made.

**NOTE:** If mechanical adjustment of the LVDT's core or body is difficult or impossible, make this adjustment as close as possible and then adjust the **Zero** control to obtain 0 V DC output. It is important that the LVDT core be within about 5% of its true null position to ensure that the full scale core displacement is within the LVDT's rated linear range. Offsets of more than about 5% may result in non-linear outputs at or near full scale displacement.

Move the LVDT's core to "plus" full scale displacement and adjust the **Span** control to obtain a reading of 10 V DC. Outputs of less than 10 V DC may also be obtained by adjustment of the **Span** control (e.g. 5 V DC). If the desired full scale output cannot be obtained by adjusting the **Span** control, reset the coarse gain jumpers to the next higher or lower setting by following the process shown in *COARSE GAIN SELECTION* on page 6, and then re-adjust the **Span** control to obtain the desired full scale output DC voltage.

Now move the LVDT's core to its "minus" full scale position. The output should be -10 V DC. If it is not, adjust the **Zero** control to obtain a reading of -10 V DC. Move the core back to the "plus" full scale position and readjust the **Span** control to obtain a 10 V DC reading. Repeat these two steps as needed to ensure the proper output at both extremes of the core travel. The module is now properly set up for bipolar voltage output operation.

## UNIPOLAR VOLTAGE OUTPUT CALIBRATION

The module has 100% zero offset capability, which allows a unipolar voltage output over the full range of the LVDT. Follow the instructions in the previous section, *BIPOLAR VOLTAGE OUTPUT CALIBRATION*, for full scale output, but adjust the **Span** control for *half* the desired full scale output (e.g., 5 V DC). Move the LVDT's core to "minus" full scale displacement and adjust the **Zero** control for 0 V DC output. Move the LVDT's core to "plus" full scale displacement and adjust the **Span** control for the desired full scale output. Repeat the last two steps to ensure proper calibration. The module is now set up for unipolar output.

## CURRENT LOOP OUTPUT CALIBRATION

To calibrate an LVC-2412 for current output, establish a current loop between Terminals 5 and 6 with a minimum loop resistance of 50 Ohms. Remove the LVDT secondary wire, usually Red (A), from Terminal 7. Insert a temporary jumper between terminals 7 and 9 (this jumper will be removed after zero adjustment). Apply DC power to unit and allow a 3-5 minute warm-up. Adjust the **Zero** control for a loop current of 12 mA. De-energize module, remove the jumper from Terminals 7 and 9, and re-connect the secondary wire Red (A) to Terminal 7. Re-apply DC power to the module. Move the LVDT's core or body to obtain 12 mA again. This position is the true null position of the sensor and the point from which subsequent measurements are made.

**NOTE:** If mechanical adjustment of the LVDT's core or body is difficult or impossible, make this adjustment as close as possible and then adjust the **Zero** control to obtain 12 mA. It is important that the LVDT's core be within about 5% of its true null position to insure that full scale displacement is within the LVDT's rated linear range. Offsets of more than about 5% may result in non-linear results at or near full scale displacement.

Move the LVDT's core to its "plus" full scale displacement and adjust the **Span** control to obtain a reading of 20 mA. Return the core to "minus" full scale position and adjust the **Zero** control to obtain a reading of 4 mA. Move the core to the "plus" full scale position and readjust the **Span** control to obtain a 20 mA reading. Repeat these last two steps as needed to ensure the proper current output at both extremes of the core travel. The module is now ready for current loop output operation.

## **LVRT AND VR HALF- BRIDGE CONNECTIONS**

The LVC-2412 can be used to operate half-bridge style gaging probes and most of the LVRTs commonly used in power plant applications. These sensors usually have only 3 connections that are designated as *input high*, *mid-tap output*, and *input/output low*. Connect *input high* to terminal 8, *mid-tap output* to terminal 7, and *input/output low* to terminal 11 of the module.

Half bridge sensors typically have lower sensitivity than an LVDT of comparable range, so to have sufficient range of **Span** adjustment, it may be necessary to modify the coarse gain jumper selections according to the directions on pages 6 and 7. Other set-up processes, such as excitation frequency selection, master/slave synchronizing, output signal calibration, and directional sense correction are the same as for operation with an LVDT.

## DIRECTIONAL SENSE

If the slope of the analog voltage or current loop output is the reverse of the desired slope, i.e., if the output voltage or current increases or decreases opposite to the desired direction of core motion, interchange (reverse) the sensor's connections to the module's terminals 8 and 11.

## OUTLINE DIMENSIONS

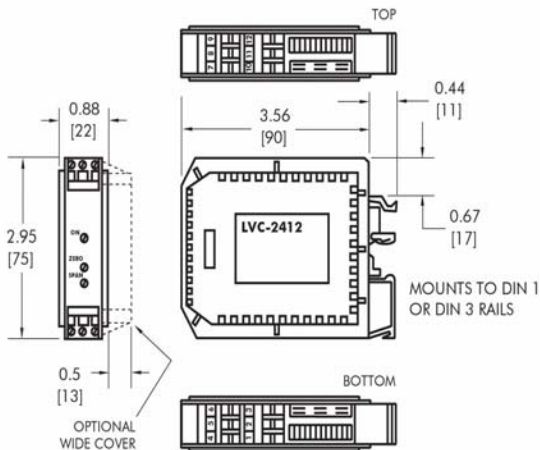

Form 1080, Rev A

©2004 by Howard A. Schaevitz Technologies, Inc.

Macro Sensors is a registered trademark of Howard A. Schaevitz Technologies, Inc.