

LVC 2402 Series

24 Volt DC Operated LVDT Signal Conditioner



Description

The Macro Sensors LVC-2402 is a single channel signal conditioner that operates on 24 Volts DC power to support any standard LVDT. Designed expressly for use in systems with PLCs and mini-PLCs, it offers the user a choice of three analog outputs: 0 to ± 10 V DC, 0 to 10 V DC, or 4 to 20 mA (sourcing) in a 3- or 4-wire current loop configuration. Unlike other 24 Volt LVDT signal conditioners, an LVC-2402's 24 Volt DC input power is fully isolated from its analog outputs. This allows it to be connected in either a 4-wire isolated I/O configuration, or in a 3-wire common ground system in which the power ground is connected to the output signal's ground. To provide maximum output flexibility, the 4-20 mA current loop output does not track the voltage output.

The LVC-2402 is packaged in a DIN-rail mounting thermoplastic case with recessed screw-clamp terminals for all connections and front-panel-accessible span and zero adjustments. It uses a time-proven ASIC to produce a low distortion sine wave to excite the LVDT and a synchronous demodulator to convert the LVDT's AC output to more useful DC voltage proportional to core position. Additional circuitry regulates the DC power operating the ASIC and

Features

- DIN-rail mountable
- DC voltage or current output
- Outputs fully isolated from power
- Non-interactive adjustments
- No phase adjustment needed
- Supports all standard LVDTs

User Selectable Features

- 0 to ± 10 V, 0 to 10 V, or 4 to 20 mA output
- 1.5 or 3.0 Vrms LVDT excitation
- 3, 5, or 10 kHz excitation frequency
- Master/slave excitation synchronization

provides span and zero adjustability, a 2-pole low pass output filter, and the voltage-to-current conversion that drives the 4-20 mA current loop output.

Besides having an externally adjustable span control, the LVC-2402 also incorporates movable coarse gain jumpers which allow it to operate over an LVDT full scale output signal range greater than 50 to 1. The external zero control permits output offset adjustment from -100% to +100% of full scale output. The span and zero controls do not interact with each other. The LVC-2402 does not require a phase adjustment control, so it can work satisfactorily with reasonably long cables between it and the LVDT.

By shifting removable jumpers internally in the LVC-2402, a user can choose 3, 5, or 10 kHz nominal excitation frequencies at a level of 3 Volts rms for driving normal LVDTs, changeable to 1.5 Volts rms for operating LVDTs with low primary impedance. For multiple channel applications, several LVC-2402 modules can be connected together in master/slave mode to synchronize their excitation oscillator frequency, thereby eliminating heterodyning, spurious beat frequency signals, cross talk, and intermodulation effects.

General Specifications

- Power Input:** 24 Volts DC $\pm 10\%$, 100 mA max.
- LVDT Excitation Output:** 3.0 Vrms (nominal) for primary impedance $\geq 200\Omega$
1.5 Vrms (nominal) for primary impedance $< 200\Omega$
- LVDT Excitation Frequency:** 3, 5, or 10 kHz (nominal)
- Input Sensitivity Range:** 100 mVrms to 5.5 Vrms produces full scale output
- Full Scale Outputs:** 0 to ± 10 V DC, 5 mA max.
0 to 10 V DC, 5 mA max.
4 to 20 mA sourcing, 500 Ω maximum loop resistance
- Output Non-linearity:** $\pm 0.01\%$ of full scale output max.
- Output Noise / Ripple:** 5 mVrms max.
25 μ Arms max.
- Frequency Response (-3dB):** 250 Hz (nominal)
- Operating Temperature:** 0°F to +160°F
(-20°C to +70°C)
- Thermal Coefficient of Sensitivity:** 0.005% of FSO/°F (nominal)
(0.01% of FSO/°C nominal)

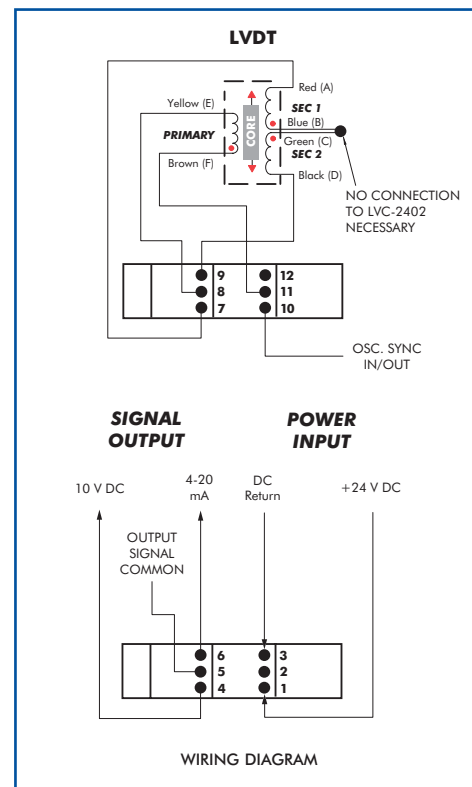
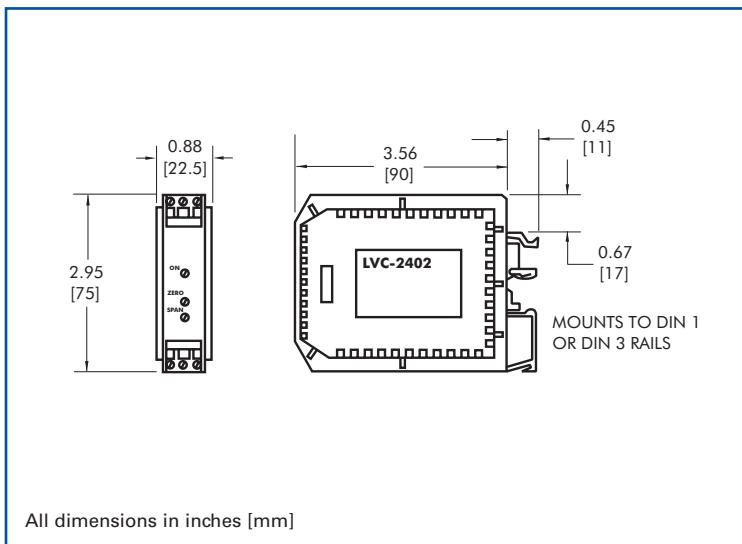

Ordering Information

Order model LVC-2402
 For specifications on other Macro Sensors LVDT signal conditioners, please visit our website at www.macrosensors.com.



Innovators in Position Sensing

All specifications subject to change without notice.
 © 2003 Macro Sensors 03/06/03

7300 US Route 130 North, Bldg. 22
 Pennsauken, NJ 08110-1541 USA
 tel: 856-662-8000
 fax: 856-317-1005
www.macrosensors.com
lvds@macrosensors.com

